



Εγχειρίδιο Χρήστη



User Manual



Bedienungsanleitung



Manual de usuario



Manuale utente



Manuel d'utilisation



Επίγεια Ψηφιακή Κεραία UHF 5G LTE 21-48



Digital Terrestrial Antenna UHF 5G LTE 21-48



Digitale Terrestrische Antenne UHF 5G LTE 21-48



Antena Digital Terrestre UHF 5G LTE 21-48



Antenna Digitale Terrestre UHF 5G LTE 21-48



Antenne Terrestre Numérique UHF 5G LTE 21-48



## Τεχνικά Χαρακτηριστικά / Technical Data / Technische Daten / Características Técnicas / Caratteristiche Tecniche / Données Techniques

Μοντέλο / Model / Modell / Modelo / Modello / Modèle	YAGI 12db
Τύπος Κεραίας / Antenna type / Antennentyp / Tipo de antena / Tipo di antenna / Type d'antenne	UHF
Κανάλια λήψης / Channels / Kanäle / Canales / Canali / Chaînes	21-48
Φάσμα συχνοτήτων λήψης / Frequency Range / Frequenzbereich / Rango de frecuencia / Gamma di frequenza / Gamme de fréquences	470-694Mhz
Αποκοπή 5G LTE / 5G LTE Protection / 5G LTE Schutz / Protección 5G LTE / Protezione 5G LTE / Protection 5G LTE	✓
Απολαβή / Gain / Verstärkung / Ganância / Guadagno / Gain	12dB
Σύνθετη Αντίσταση / Impedance / Impedanz / Impedancia / Impedenza / Impédance	75Ω
Διάμετρος ιστού στερέωσης / Mast Diameter Support / Mastdurchmesser Unterstützung / Soporte de diámetro de mástil / Supporto diametro albero / Support de diamètre de mât	20...50mm
Εφαρμογή / Application / Anwendung / Aplicación / Applicazione / Application	Outdoor
Χρώμα / Color / Farbe / Color / Colore / Couleur	Μπλε / Blue / Blau / Azul / Blu / Bleu
Μήκος / Length / Länge / Longitud / Lunghezza / Longueur	101cm
EAN Barcode	5200378402856
Συσκευασία / Packing / Verpackung / Embalaje / Imballaggio / Emballage	Giftbox
Ποσότητα συσκευασίας / Packing Quantity / Verpackungsmenge / Quantité d'emballage / Quantità di imballaggio / Quantité d'emballage	10pcs

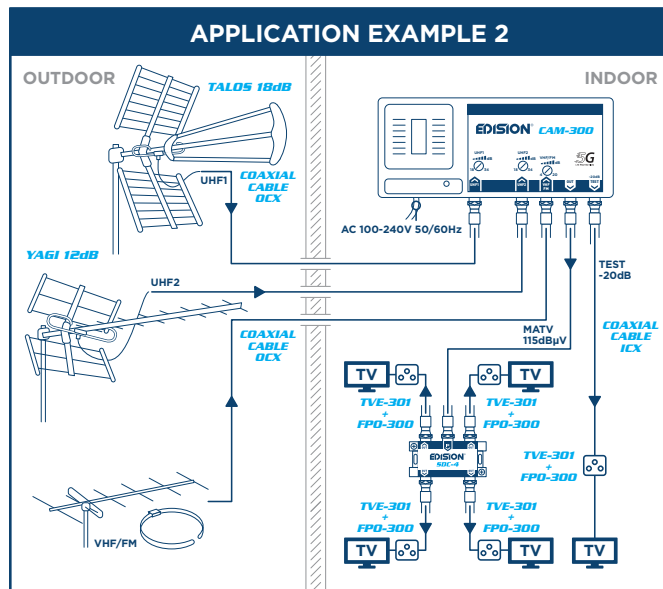
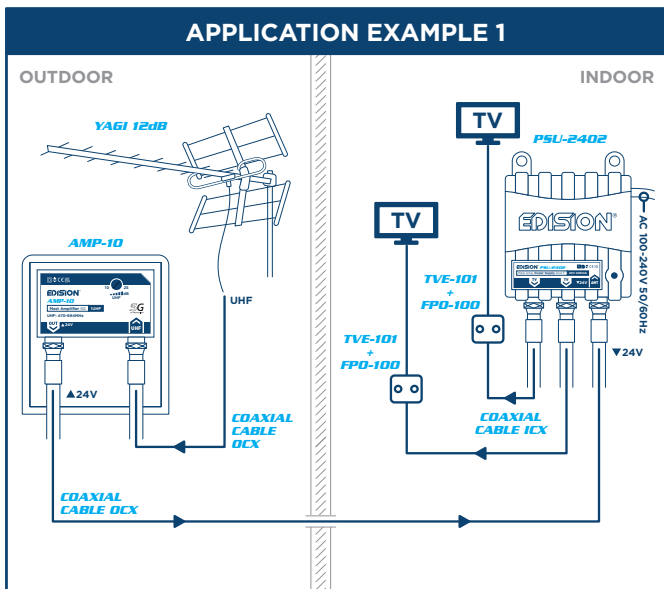

# YAGI 12db

Digital Terrestrial Antenna UHF 5G LTE (21-48)

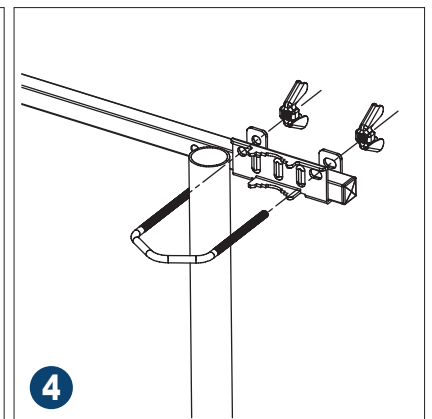
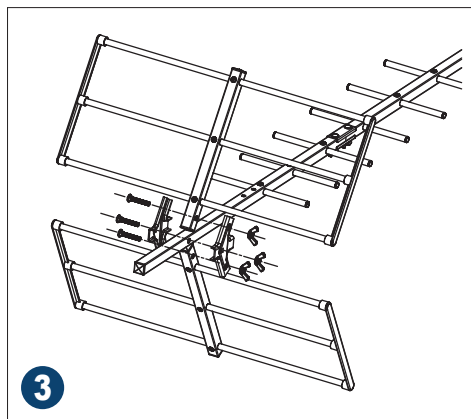
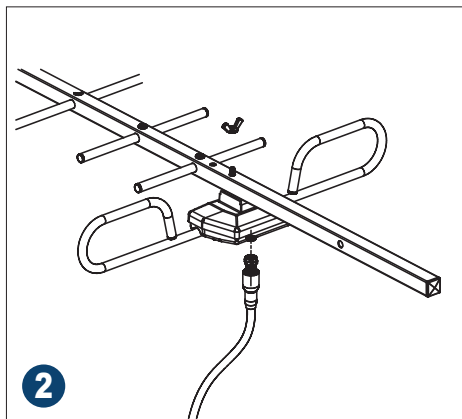
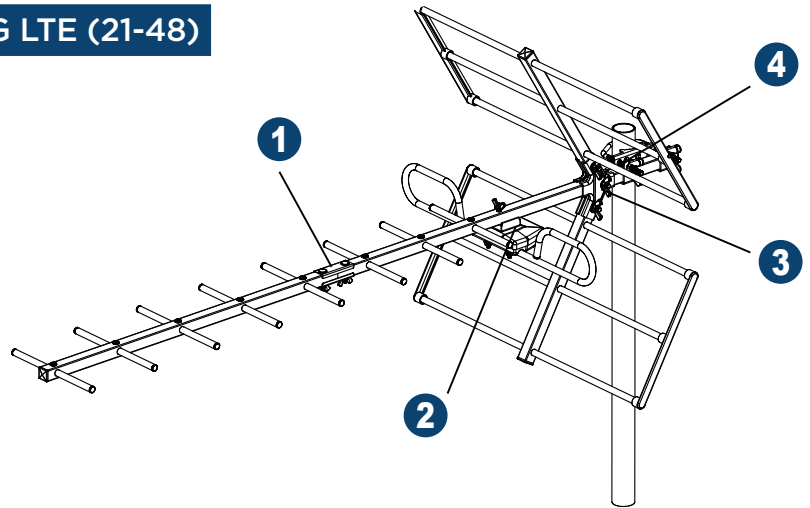
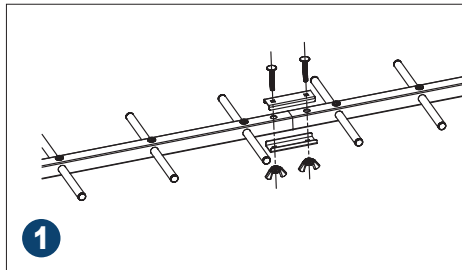

**GR** Για περισσότερες πληροφορίες, παρακαλώ επικοινωνήστε στο [support@edision.gr](mailto:support@edision.gr) ή στο DOWNLOAD CENTER: [www.edision.gr/el/support](http://www.edision.gr/el/support)

**UK** For more information, please contact [support@edision.gr](mailto:support@edision.gr) or visit the DOWNLOAD CENTER: [www.edision.gr/en/support](http://www.edision.gr/en/support)

**DE** Für mehr Informationen, bitte wenden Sie sich an [support@edision.gr](mailto:support@edision.gr) oder im DOWNLOAD CENTER: [www.edision.gr/de/support](http://www.edision.gr/de/support)

**ES** Para más información, contáctate [support@edision.gr](mailto:support@edision.gr) o visita el CENTRO DOWNLOAD: [www.edision.gr/en/support](http://www.edision.gr/en/support)

**IT** Per maggiori informazioni, veuillez contacter [support@edision.gr](mailto:support@edision.gr) oppure visitare il DOWNLOAD CENTER: [www.edision.gr/en/support](http://www.edision.gr/en/support)

**FR** Pour plus d'informations, veuillez contacter [support@edision.gr](mailto:support@edision.gr) ou visitez le DOWNLOAD CENTER: [www.edision.gr/en/support](http://www.edision.gr/en/support)



SCAN ME!

**GR** Το πιστοποιητικό CE του προϊόντος είναι διαθέσιμο στην ιστοσελίδα μας, στον σύνδεσμο: [www.edision.gr/el/support](http://www.edision.gr/el/support)

**UK** The CE certificate of the product is available on our webpage, by visiting this link: [www.edision.gr/en/support](http://www.edision.gr/en/support)

**DE** Das CE Zertifikat des Produktes finden Sie auf unserer Website unter: [www.edision.gr/en/support](http://www.edision.gr/en/support)

**ES** El certificado CE del producto está disponible en nuestra página web, visitando este enlace: [www.edision.gr/en/support](http://www.edision.gr/en/support)

**IT** Il certificato CE del prodotto è disponibile sulla nostra pagina web, visitando questo link: [www.edision.gr/en/support](http://www.edision.gr/en/support)

**FR** Le certificat CE du produit est disponible sur notre page web, en visitant ce lien: [www.edision.gr/en/support](http://www.edision.gr/en/support)

